



Driving Innovation ♦ Delivering Results



Water Management Research & Development

Water Nexus – Water Treatment Technologies

2016 Mastering the Subsurface Through Technology Innovation
and Collaboration: Carbon Storage and Oil and Natural Gas
Technologies Review Meeting

Jessica Mullen, Ph.D.
Federal Project Manager
Enabling Technologies and Partnerships Team
08/17/2016



U.S. DEPARTMENT OF
ENERGY

National Energy
Technology Laboratory

- **Introduction**
- **Crosscutting Research & Analysis Program (formerly CTRP)**
- **Water Management Research & Development Program Overview**
- **Water Management Treatment Project Highlights**
- **Summary & Closing Remarks**

NETL: THE Fossil Energy Laboratory

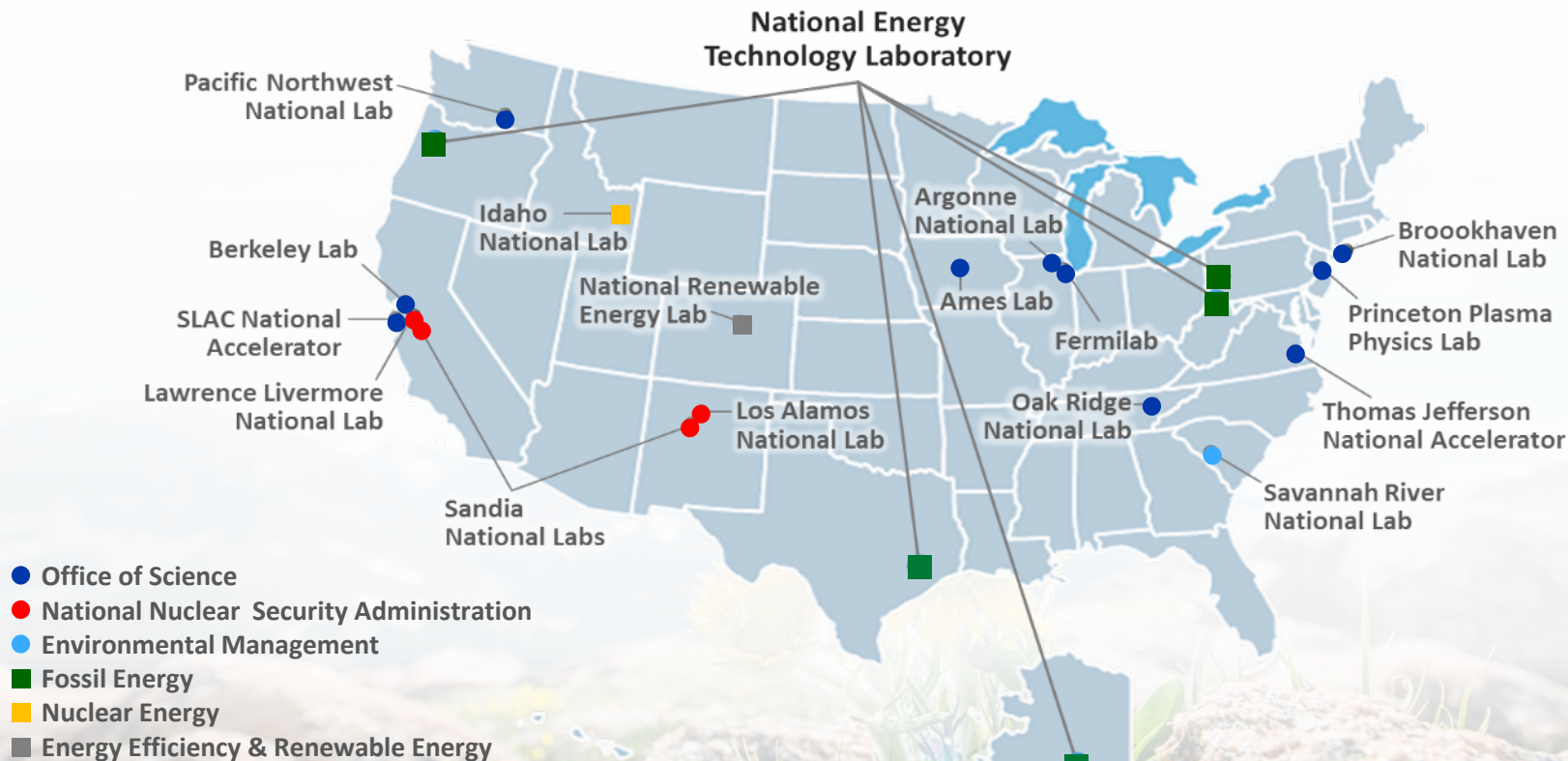

NETL's mission is to discover, integrate, and mature technology solutions to enhance the Nation's energy foundation and protect the environment for future generations

Crosscutting Research & Analysis

Targets Support Across Multiple Program Areas



National Energy Independence and Reduced Emissions



Key Technologies

- High Performance Materials
- Sensors & Controls
- Simulation-Based Engineering
- Water Management R&D
- Innovative Energy Concepts

Key Drivers

- Higher Efficiency
- Process Intensification
- Improve Design Tools
- Improve Process Control
- Lower Water Use

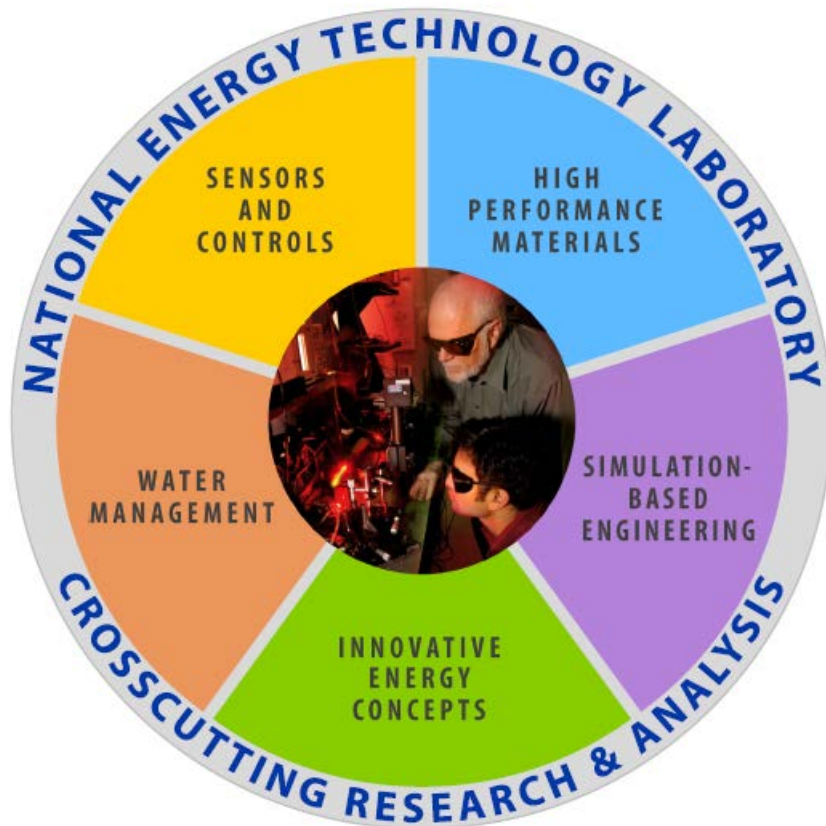

- ❑ **High Performance Materials**
 - Ultrasupercritical Boilers & Turbines
 - High-strength metallic & intermetallic alloys
 - Computational Material Modeling
- ❑ **Sensors and Controls**
 - **Advanced Sensing**
 - **Distributed Intelligent Control**
 - **High Temperature & Harsh Environment Application**
- ❑ **Simulation-based Engineering**
 - High fidelity models of advanced power systems
 - Advanced power system simulations
 - Carbon Capture Simulation Initiative
 - National Risk Assessment Partnership
- ❑ **Innovative Energy Concepts**
 - Direct Power Extraction
 - Thermoelectric Materials
 - Pulse Detonation/Pressure Wave Combustion
- ❑ **Water Management R&D**
 - **Advanced / Novel Heat Transfer and Cooling Systems**
 - **Water Treatment and Reuse**
 - **Process Efficiency and Heat Utilization**
 - **Data, Modeling, and Analysis**

Crosscutting Research & Analysis



FOSSIL ENERGY RESEARCH PROGRAM

Readying Advanced Technology for Commercial Deployment

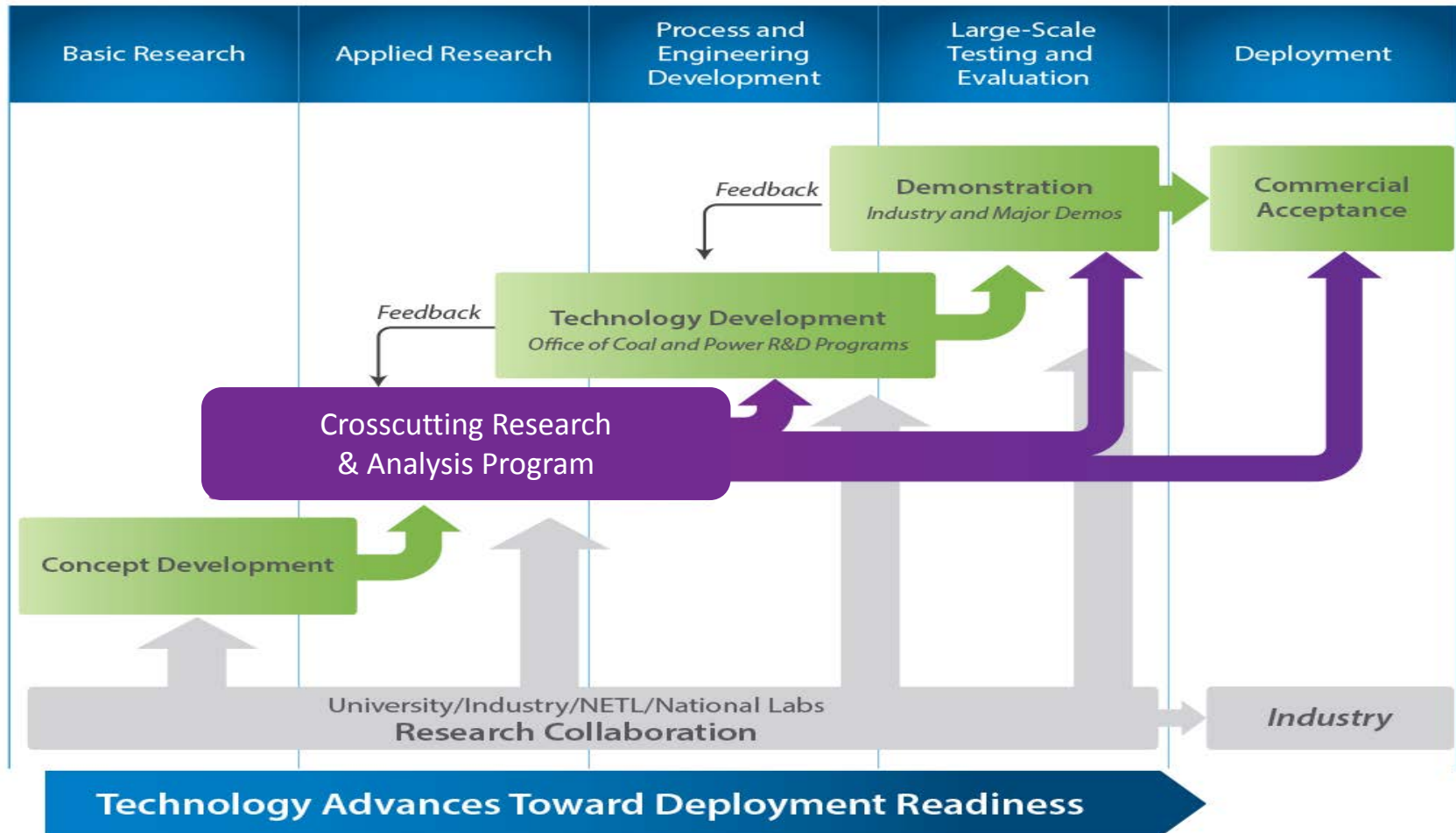

Crosscutting Research & Analysis

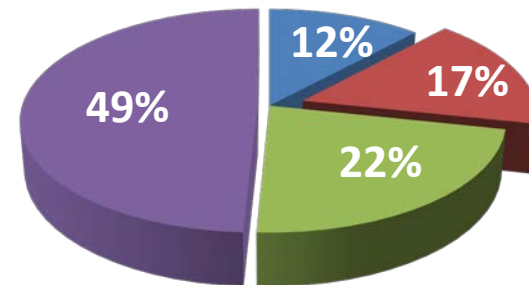
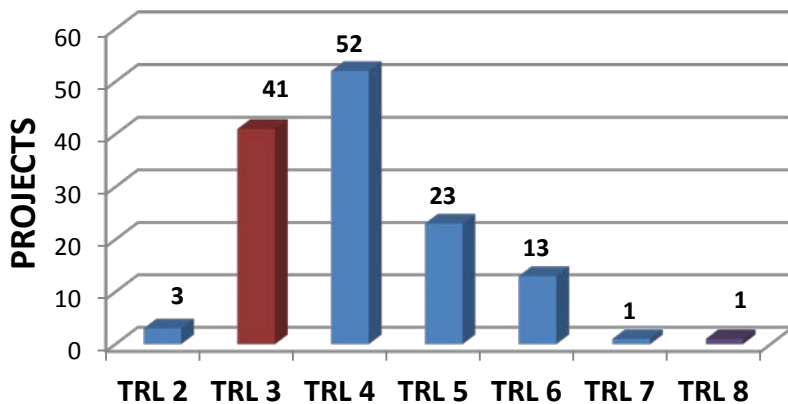
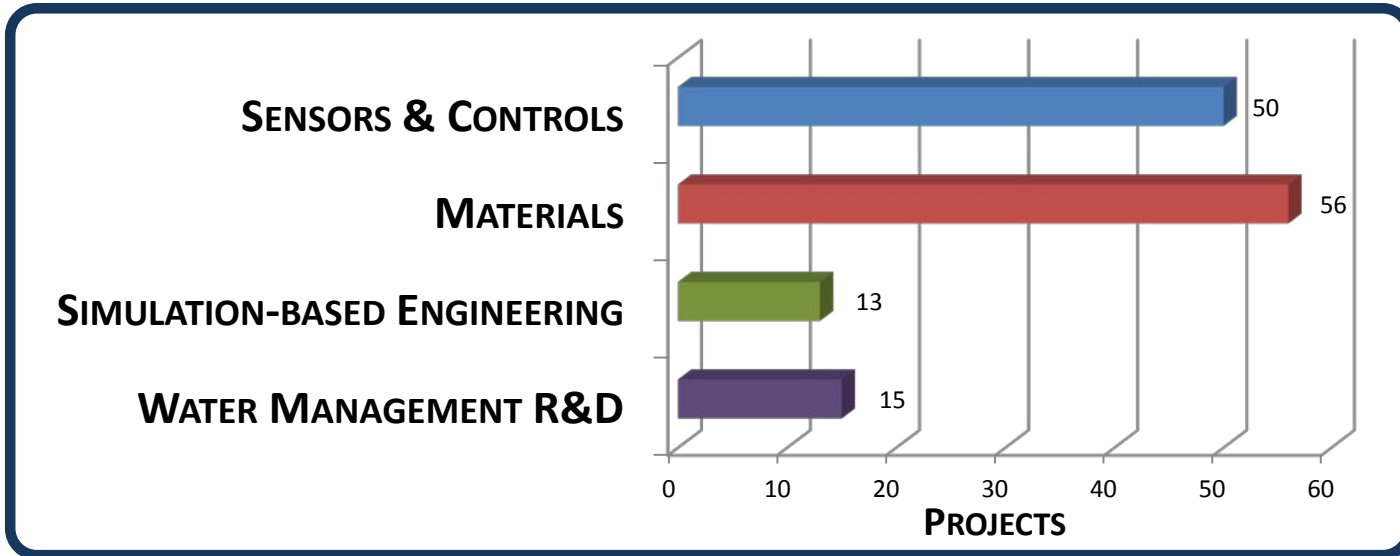

■ NETL ■ National Laboratory ■ Industry ■ University

Why Water Management R&D?



Public Issue: Water Withdrawals and Consumptive Use

Thermo-electric Power Large User of Water, Relatively Small Consumer

New & Existing Power Plants Must Optimize Water Use

- Optimize the freshwater efficiency of energy production, electricity generation, and end use systems for Today's and Tomorrow's Power Plant Systems
- Optimize the energy efficiency of water management, treatment, distribution, and end use systems
- Enhance the reliability and resilience of energy and water systems
- Increase safe and productive use of nontraditional water sources (e.g. MWT, Produced Waters)
- Promote responsible energy operations with respect to water quality, ecosystem, and seismic impacts
- Exploit productive synergies among water and energy systems

U.S. Freshwater Withdrawal¹

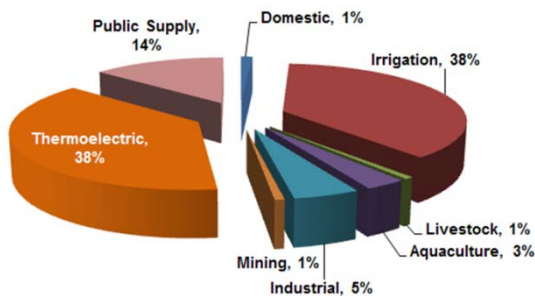

**2010 Thermolectric
Freshwater Requirements:**
Withdrawal: ~ 117 BGD
Consumption: ~ 4 BGD

**80% Increase in water consumption for
CO₂ Capture & Storage**

U.S. Freshwater Consumption²

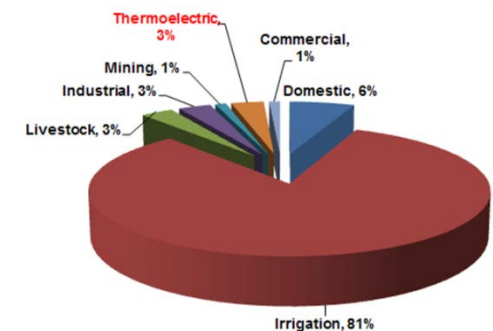

Water Research Opportunities

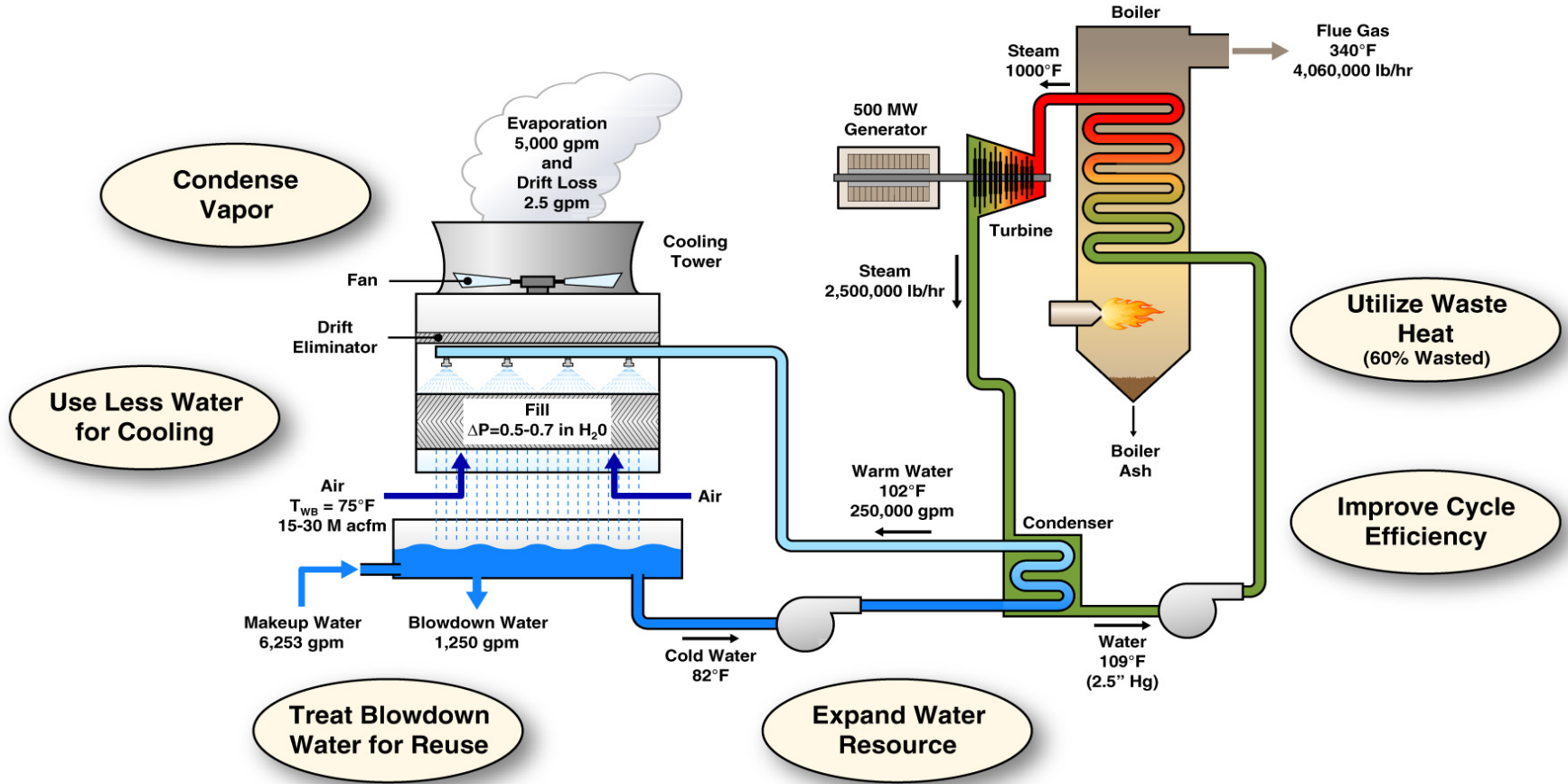

Innovation Priorities: Advancing cooling technologies, and applying novel water treatment and waste heat concepts to improve efficiency and reduce water use

Water Management Research Focus Areas



- **Advanced / Novel Heat Transfer and Cooling Systems**
 - Wet, Dry, Hybrid
 - Incremental & Step Change Improvements
 - Advanced Manufacturing of Recuperators for Combustion Turbines
- **Water Treatment and Reuse**
 - Economic Pathways for Zero Liquid Discharge
 - Treatment of high TDS Waters (promote greater Water Reuse – collaboration with Carbon Storage)
- **Process Efficiency and Heat Utilization:**
 - Pathways for produce more power per unit of water withdrawn, consumed, and treated
 - Utilization of Low-Grade Heat
 - Bottoming Cycles
- **Data, Modeling and Analysis**
 - Tools to enable regional and plant level decision making
 - Develop a National Water Atlas
- **Breakthrough or Out of the Box**
 - Low / No water FE based Systems, Distributed Generation, Grid Upgrades

Water Management Project Portfolio (All Programs)



Process Efficiency and Heat Utilization

- Institute of Gas Technology dba Gas Technology Institute (ETP)
- Southern Company Services, Inc. (ETP)
- Porifera, Inc. (ETP)
- Carnegie Mellon University (ETP)
- West Virginia State University (HBCU/OMI)

Data, Modeling, and Analysis

- Sandia National Laboratories (FWP)

Water Treatment and Reuse

- General Electric Company** (ETP)
- Research Triangle Institute** (ETP)
- Southern Research Institute (ETP)
- University of Pittsburgh (ETP)
- University of Illinois (ETP)
- Ohio University (ETP)
- NanoSonic, Inc. (SBIR)
- Sporian Microsystems, Inc. (SBIR)
- NETL-Research & Innovation Center (FWP)
- LANL (FWP)
- University of Alabama at Birmingham (UCR)

*** Multiple projects
(UCR) University Coal Research, (SBIR) Small Business Innovative Research,
(HBCU/OMI) Historically Black Colleges & Universities and Other Minority Institutions
(ETP) Programmatic FOAs, (FWP) Field Work Proposal*

Project Highlights

- **“Innovative Concepts for Managing Water in Fossil Fuel Based Energy Systems ”**
- **Subtopic 1-B “Low Cost Treatment of Produced Waters ”**
 - Concentrated brine solution, total dissolved solids level of up to 320,000 parts per million (ppm), 180,000 ppm as an average
- **Projects started October 2014 and January 2015**
 - 24-month duration
 - ~\$500k each (+20% cost share)

Treatment of Produced Water from Carbon Sequestration Sites for Water Reuse, Mineral Recovery and Carbon Utilization



• Project Objective & Scope

- Demonstrate the feasibility of a novel and innovative approach for managing and maximizing reuse of waters produced for reservoir pressure and plume management during CO₂ injection for storage.

The project's scope of work includes:

- Prediction of the composition and mass of produced waters from CO₂ sequestration sites.
- Creating high level configuration system designs to use for mass, energy and cost estimation.
- Development of solidification/stabilization to immobilize contaminants in the concentrated waste brine and solids from the evaporation system.
- Examination of potential opportunities for recovery of strategic and rare earth minerals (SREMs), CO₂ utilization, and water reuse.

• Anticipated Project Benefits

- Will allow for the treatment of produced waters with large TDS that could not normally be treated using traditional membrane processes.
- Will reduce the negative environmental and health impacts of contaminants in produced waters.

• Accomplishments

- Identified formation characteristics of four CO₂ sequestration sites.
- Identified Vibratory Shear Enhanced Processing (VSEP) and Heartland Concentrator Process (HCP) for integrated evaporation system.
- Tested percolation column for use in solidification/stabilization process.

• Project Status

- Developing a strategic plan to align local natural resource utilization, regional energy demands, and global emissions reduction requirements.
- Designing an economically feasible process for long term CO₂ capture, sequestration, and treatment of produced water by-products is in progress.

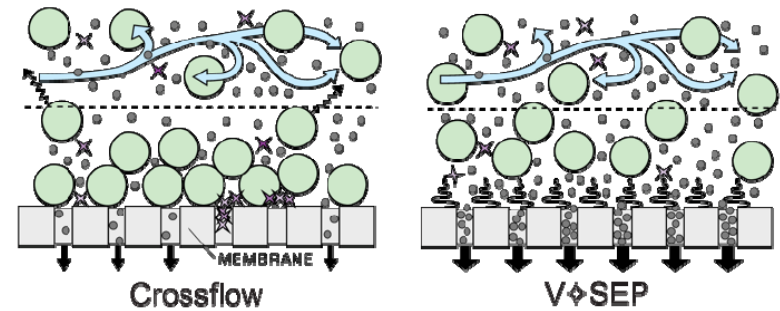

VSEP technology, oscillating resonant motion causes solids to hover above membrane.



Percolation column test setup.

Development of Membrane Distillation Technology Utilizing Waste Heat for Treatment of High Salinity Wastewaters



Project Objective & Scope

- Evaluate the feasibility of using membrane distillation (MD) technology to treat high salinity wastewaters generated during unconventional gas production or CO₂ sequestration, utilizing waste heat that is available in thermoelectric power plants or compressor stations. The project will:
 - Conduct laboratory-scale studies with synthetic and actual wastewaters to assess capabilities and limitations of MD technology and define key design and operating parameters for high salinity brines generated by unconventional gas extraction or active CO₂ reservoir management.
 - Perform systems-level analysis and integration of MD process with low-grade heat sources.
 - Conduct a preliminary techno-economic assessment of the proposed integrated system in comparison to competing technologies as well as for the system that uses natural gas as fuel source for MD treatment of high salinity wastewaters in formations where natural gas is the main target resource (i.e., Marcellus Shale) and where it is not (i.e., Bakken and Eagle Ford).

Anticipated Project Benefits

- Will advance the use of alternative sources of energy for wastewater treatment.
- Will promote the recycle and reuse of wastewater.
- Will reduce the energy footprint and enhance the mobility of treatment systems.
- Will enhance economic and environmental performance of MD technology.

Accomplishments

- Found that direct contact membrane distillation (DCMD) can be used to concentrate produced water.
- Developed ASPEN simulation to estimate flux and temperature profiles for a scaled-up DCMD process
- Quantified waste heat from natural gas compressor stations in PA.

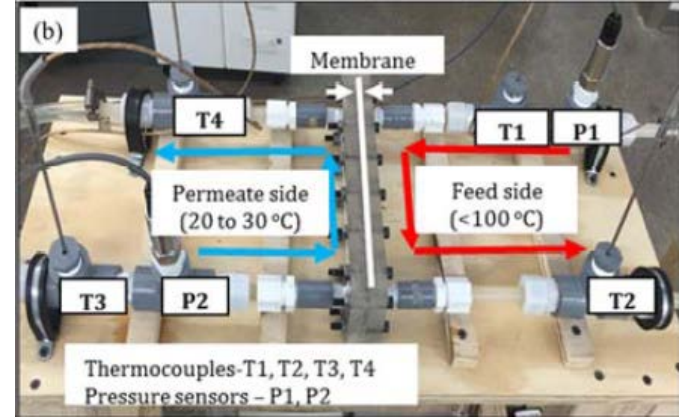

DCMD test module.

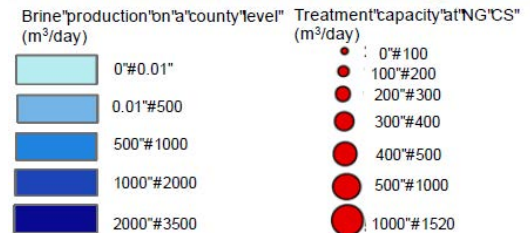
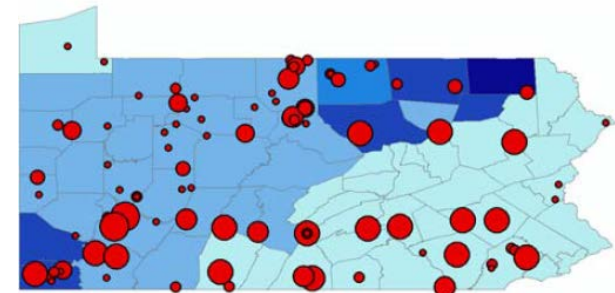

Produced water that can be treated at NGCS in PA (only 54% of waste heat from NGCS is required to achieve 30% salinity).

Fouling-Resistant Membranes for Treating Concentrated Brines for Water Reuse in Advanced Energy Systems



- **Project Objective & Scope**

- Develop and demonstrate bench-scale feasibility of a low-cost, novel water treatment process using electrically conductive membrane distillation (ECMD) for the reuse of water contained in concentrated brines that are generated during fossil fuel extraction/processing. This project will:
 - Demonstrate membrane distillation to recover at least 50% of wastewater with high total dissolved solids (TDS) concentration.
 - Develop ECMD membranes having improved fouling resistance when compared to the relative flux of a non-conductive membrane during the treatment of highly scaling water.
 - Develop experimentally validated models that can predict the separation performance achievable with the new conductive membrane types.
 - Develop preliminary design of a full-scale ECMD module.
 - Perform techno-economic and environmental analyses of water treatment processes utilizing electrically conductive membranes.

- **Anticipated Project Benefits**

- Could lead to at least 50% reuse of treated effluent for produced water at 180,000 mg/L.
- Could lead to 35% to > 90% reduction in costs associated with water treatment/disposal (80% reduction when compared to deep well injection).
- Could lead to improvement in membrane fouling relative to existing membranes.

- **Accomplishments**

- Found that ECMD operation has a repeatable and significant effect on increasing water recovery.

- **Project Status**

- Performing testing with real, complex, high TDS wastewater.
- Modeling scalant-membrane interaction.
- Designing prototype full-scale ECMD module.
- Performing preliminary process integration analysis.

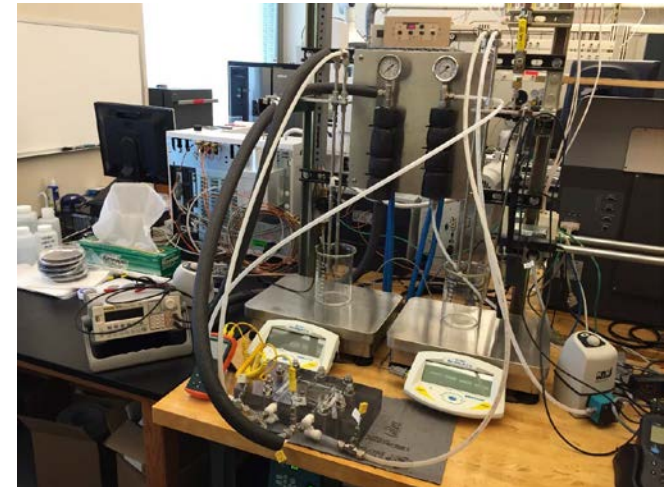

ECMD plate-and-frame flat sheet single membrane test cell.

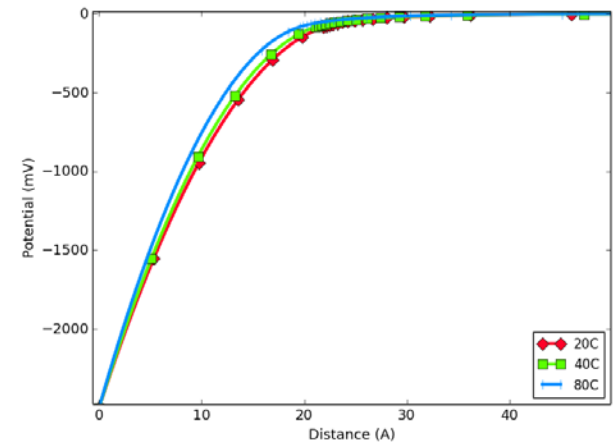

The effect of the charged surface is minimally impacted by temperature.

- **Project Objective & Scope**

- The goals of the proposed project are to establish the technical and economic feasibility of multi-phase turbo-expander based water desalination process and achieve a cost of water treatment at least 20% less than the current state of the art. The project will:

- Develop a novel brine freeze desalination process based on brine cooling by expansion of a compressed air/brine stream in a turbo-expander.
- Develop design tools for the expander.
- Validate the tools using experimental data.
- Develop the process design.
- Confirm process economics.
- Demonstrate the technology feasibility.

- **Anticipated Project Benefits**

- Has potential to reduce treatment costs of high salinity water by at least 20% in comparison to thermal evaporation.
- Has fewer corrosion problems than thermal evaporation.
- Less expensive materials can be used in comparison with thermal evaporation.
- Process developed will be well suited for mobile applications.

- **Accomplishments**

- Performed water freeze testing, results showed indication of ability to achieve 100% brine freeze.
- Characterized ice/salt structure.

- **Project Status**

- Completed.



Water desalination experimental setup test rig.

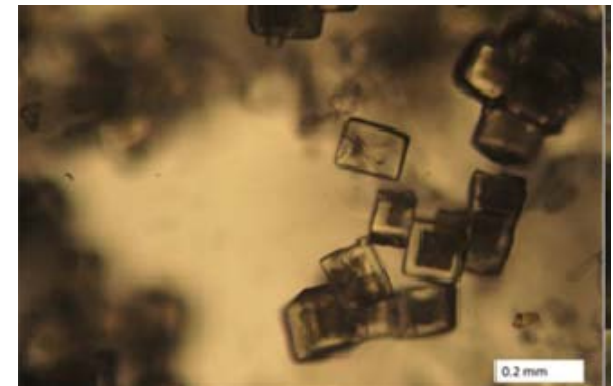

Salt crystals separated from ice under slow freeze conditions.

An Integrated Supercritical System for Efficient Produced Water Treatment and Power Generation



- **Project Objective & Scope**
 - Evaluate the feasibility of an innovative, integrated, supercritical (SC) cogeneration system for cost-effective treatment of produced waters from carbon dioxide (CO₂) sequestration, oilfields, and coal-bed methane (CBM) recovery. The project will:
 - Perform process simulation, thermodynamic analysis, and techno-economic evaluation of the proposed integrated system.
 - Design and test a supercritical salt precipitation system.
 - Develop and characterize advanced carbon membranes.
 - Design, assemble, and test a supercritical membrane distillation system.
- **Anticipated Project Benefits**
 - Will lead to cost-effective innovative approaches for treatment of concentrated brine with utilization of coal or natural gas/flare gas as an energy source.
 - Proposed process is deployable at produced water extraction sites particularly for large-scale CO₂ sequestration projects.
- **Accomplishments**
 - Performed simulations for a 550 MW integrated supercritical system for coal-fired and natural gas-fired boilers.
 - Laboratory-scale SC desalination system has been designed, fabricated, and tested.
 - Various carbon membranes for SC desalination have been developed.
- **Project Status**
 - Work to treat different produced water samples to high purity level is in progress.

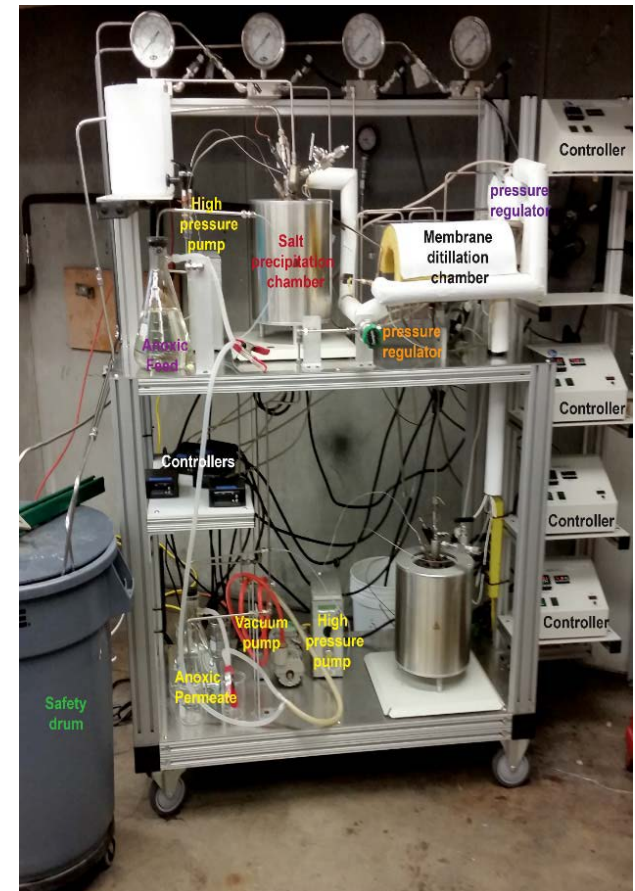

Laboratory-scale supercritical desalination system.

- **“Water Management and Treatment for Power Plant and CO₂ Storage Operations ”**
 - Multi-stage, system level water treatment technologies applicable to impaired waters with total dissolved solids level of 180,000 parts per million (ppm)
- **Projects started September 2015**
 - 18-month duration
 - ~\$750k each (+20% cost share)

Low-Energy Water Recovery from Subsurface Brines



Project Objective & Scope

- Develop and demonstrate bench-scale feasibility of a low-cost, low-energy treatment process using a non-aqueous solvent (NAS) extraction to recover water from deep aquifer brine. Specific project objectives are to:
 - Identify candidate solvents that can absorb water in one condition and release in another condition
 - Test different solvents and/or mixture of solvents for optimum water uptake and release to maximize water recovery from 180,000 ppm total dissolved solids (TDS) brine
 - Test water quality and, if necessary, develop downstream process to satisfy potable water standard
 - Develop optimum conditions to maximize the kinetics of the process
 - Develop strategies to optimize the overall process and perform techno-economic assessment for scale up

Anticipated Project Benefits

- Technology developed has a great potential to either eliminate or reduce the cost of thermal approaches that are currently the only option in practice for high-TDS waters
- Technology developed could lead to the production of potable-quality water from high-TDS wastewater sources.

Accomplishments

- Three mechanisms were developed for NAS desalination process.

Project Status

- New solvents are being selected and tested.
- CO₂, polymer, alcohol, and fatty acids will be added to a solvent to increase desalination performance.
- The NAS desalination process is being developed.

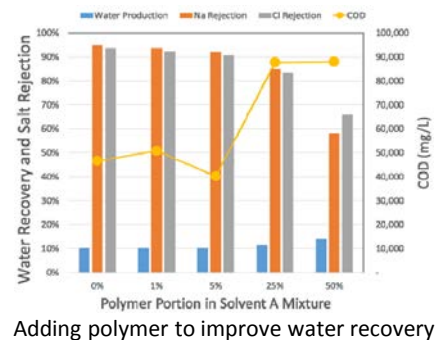
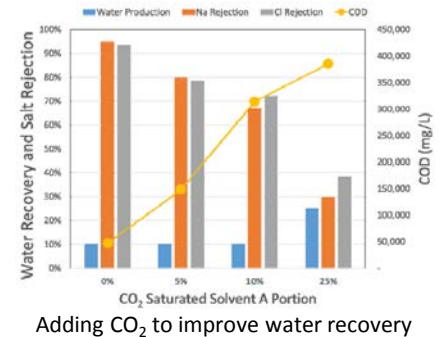
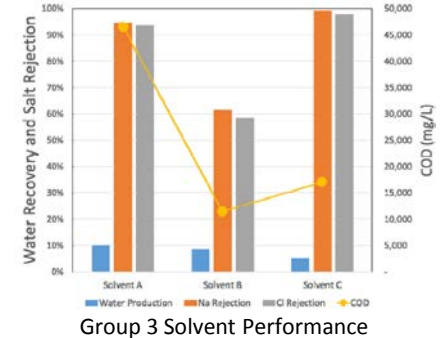

Advanced Integrated Technologies for Treatment and Reutilization of Impaired Water in Fossil Fuel-based Power Plant Systems



Project Objective & Scope

- Develop an advanced multi-stage process for treatment and reutilization of impaired water as make-up water in power plants. Project scope includes:
 - Commercial solids filtering, UV light treatment to remediate bacteria.
 - Low-cost natural zeolite to remove naturally occurring radioactive material (NORM) found in oil/gas-based impaired water.
 - Electrochemical stripping (E-stripping).
 - Selective sulfation to remove minor constituents.
 - Breakthrough supercritical water (SCW) unit design which utilizes internal heating to remove major constituents and hydrocarbons.

Anticipated Project Benefits

- Recovers 95% of impaired water as a beneficially reusable water product:
 - Capable of working with all impaired water chemistries.
 - Selective removal of minor constituents (Fe^{2+}/Fe^{3+} , Mn^{2+} , Zn^{2+} , Ru^{2+} , and Cu^{2+}).
 - Removal of all major impaired water constituents.
 - Removal of naturally occurring radioactive material (NORM) associated with oil/gas impaired water.
 - Produce non-hazardous bulk solid products for industrial/municipal applications.

Accomplishments

- For the preliminary E-stripping stage process, Fe-electrodes tested and found to be more efficient at removing minor constituents than Al-electrodes.
- Found that water density is major factor controlling total dissolved solids (TDS) removal level.
- Removed greater than 99.5% TDS from solutions containing >100k ppm TDS.

Project Status

- Improving removal efficiency of E-stripping stage.
- Evaluating TDS removal efficiency and reactor operability.
- Evaluating corrosion resistant cladding materials.

	Sample 1	Sample 2	Sample 3	Sample 4	Sample 5	Sample 6	Sample 7
Electrode material	Al	Al	Al	Al	Al	Al	Fe
Initial concentration of Zn (mg/l)	500	500	500	500	500	500	500
Current density (mA/cm ²)	4.1	4.1	4.1	4.1	4.1	4.1	4.1
Electrodes distance (mm)	10	10	10	10	20	10	10
EC time (min)	30	15	30	60	30	30	30
Concentration of NaCl (mol/l)	0	0.1	0.1	0.1	0.1	0.1	0.1
Initial pH	5.2	4.5	4.7	4.5	4.5	3.2	4.5
Final pH	3.8	4.5	4.5	4.5	4.5	4.3	4.5
Residual concentration of Zn (mg/l)	355.5	363.3	349.3	255.2	334.7	310.9	294.6
Removal (%)	29	27	31	49	33	38	41
Residual concentration of Al/Fe (mg/l)	24.4	6.7	5.4	2.2	5.5	43.4	106.5

Initial and residual metal concentration, metal removal %, residual concentration of anode after Al Electro-Coagulation (EC) and Fe EC process.

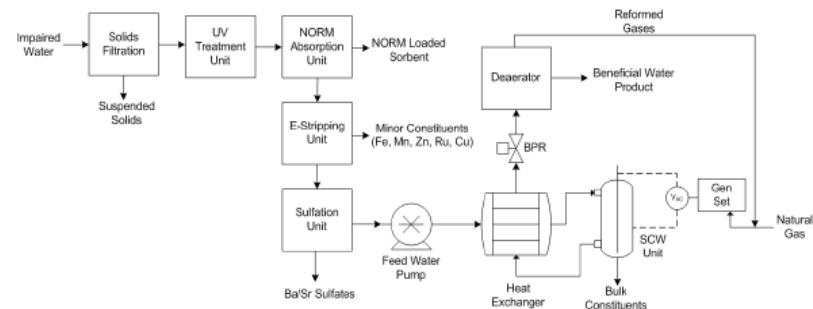

Proposed Impaired Water Treatment Process

Model-Based Extracted Water Desalination System for Carbon Sequestration



- Project Objective & Scope**
 - Leverage new technology to develop a cost-effective water recovery process from high salinity extracted formation water. This project will:
 - Define a scalable, multi-stage extracted water desalination system that yields clean water, concentrated brine, and, optionally, salt from saline brines (180,000 ppm total dissolved solids) that meets a cost target.
 - Validate the overall system performance with field-sourced water using General Electric pre-pilot and laboratory facilities.
 - Define the scope and identify a team and test location for pilot-scale implementation of the desalination system.
- Anticipated Project Benefits**
 - Successful execution of this project has the potential to dramatically increase the capacity of deep saline formations for CO₂ storage with minimal cost impact.
 - This project could also validate new, low-cost water pretreatment and desalination technologies.
- Accomplishments**
 - Compared Capex + Opex cost of forward osmosis (FO), membrane distillation (MD), humidification-dehumidification (HDH) and turbo-expander freeze alternate brine concentration technologies to the base case of falling film mechanical vapor recompression (FF-MVR).
- Project Status**
 - Refinement of pretreatment and desalination cost models via bench/pre-pilot scale runs with field-sourced extracted water.

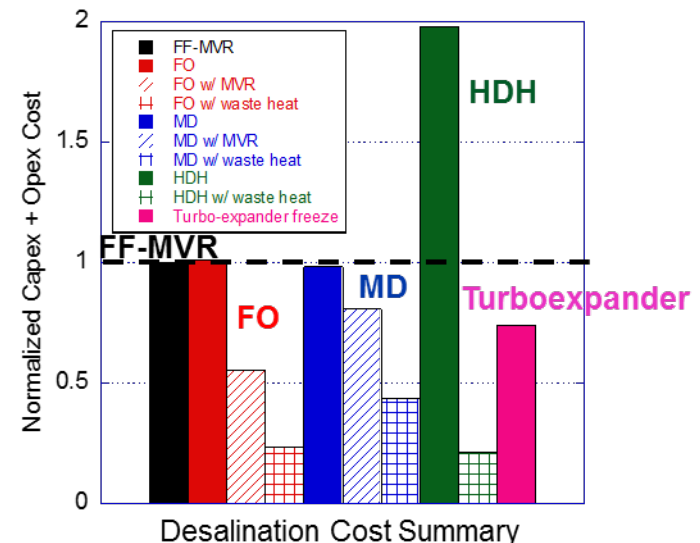
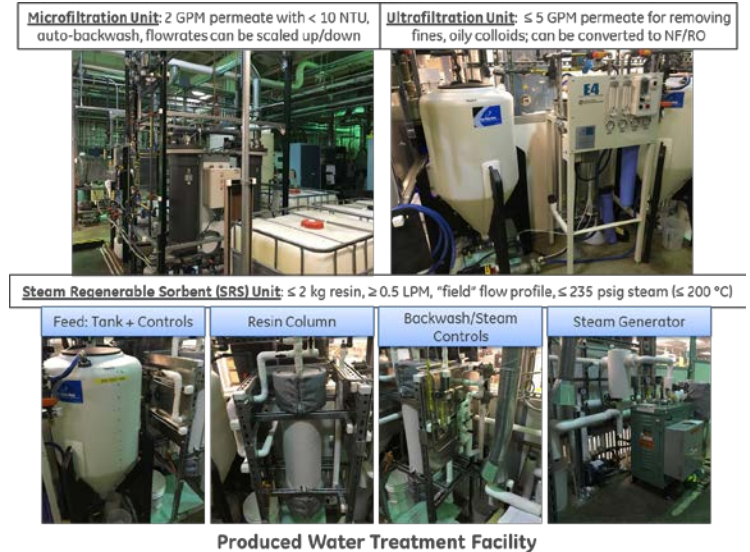

- **DOE/NETL Water Management Research & Development Program supports sustainability and improved water efficiency focusing on treatment and use of non-traditional water, water-efficient cooling, and data modeling and analysis activities.**
- **Crosscutting Research & Analysis Program**
 - Advanced / Novel Heat Transfer and Cooling Systems
 - Water Treatment and Reuse
 - Process Efficiency and Heat Utilization
 - Data, Modeling, and Analysis
- **Project Highlights**
 - NETL funded research is advancing current state of the art in many application areas of impaired water treatment.

Websites for More Information



- **Office of Fossil Energy (FE)**

<http://www.energy.gov/fe>

- **National Energy Technology Laboratory (NETL)**

<http://www.netl.doe.gov>

- **Crosscutting Research & Analysis**

<http://www.netl.doe.gov/research/coal/crosscutting>

- **2016 Crosscutting Research Portfolio Review Meeting**

<http://www.netl.doe.gov/events/conference-proceedings/2016/crosscutting>

- **Water Management Research and Development**

- Portfolio (April 2016)

<http://www.netl.doe.gov/File%20Library/Research/Coal/crosscutting%20research/CCR-Water-Management-2016.pdf>

- Webpage

<http://www.netl.doe.gov/research/coal/crosscutting/project-information#wm>

- **NETL Funding Opportunity Announcements**

<http://www.grants.gov/>

<https://www.fedconnect.net/FedConnect/Default.htm>

<http://www.netl.doe.gov/business/solicitations>

- **Robert Romanosky (Technology Manager Manager, S&T)**

Robert.Romanosky@netl.doe.gov

(304)285-4721

- **Patricia Rawls (Supervisor, ETP Team)**

Patricia.Rawls@netl.doe.gov

(412)386-5882

- **Jessica Mullen (Federal Project Manager, ETP Team)**

Jessica.Mullen@netl.doe.gov

(412)386-7540

Let's Do This Together



Partnering with NETL

[www.netl.doe.gov/
research/on-site-research/
partnering-with-us](http://www.netl.doe.gov/research/on-site-research/partnering-with-us)

Business Opportunities with NETL

www.netl.doe.gov/business

The screenshot displays the NETL website's 'ON-SITE RESEARCH' page. At the top, there is a navigation bar with links for 'Home', 'Research', 'Newsroom', and 'Business'. A search bar and the U.S. Department of Energy logo are also present. The main content area features a 'Research' sub-header and a list of links: 'Publications', 'Patents', 'Awards', 'Partnering With Us', 'About Us', 'Contacts', and 'Staff Search'. A featured article titled 'A National Energy R&D Resource since 1910' includes a video player and a brief description of NETL's research program. Below this, three columns highlight 'RESEARCH PORTFOLIO', 'RESEARCH CAPABILITIES', and 'RESEARCH INTERNSHIPS', each with a representative image and a short paragraph of text. The 'RESEARCH PORTFOLIO' section mentions contributions to energy safety and national security. The 'RESEARCH CAPABILITIES' section describes the use of state-of-the-art facilities and collaboration with external partners. The 'RESEARCH INTERNSHIPS' section details the program's goal to inspire and train students and faculty.

Acknowledgment



This report was prepared as an account of work sponsored by an agency of the United States Government. Neither the United States Government or any agency thereof, nor any of their employees, makes any warranty, express or implied, or assumes any legal liability or responsibility for the accuracy, completeness, or usefulness of any information, apparatus, product, or process disclosed, or represents that its use would not infringe privately owned rights. Reference herein to any specific commercial product, process, or service by trade name, trademark, manufacturer, or otherwise does not necessarily constitute or imply its endorsement, recommendation, or favoring by the United States Government or any agency thereof. The views and opinions of authors expressed herein do not necessarily state or reflect those of the United States Government or any agency thereof.

It's All About a Clean, Affordable Energy Future



For More Information, Contact NETL

the ENERGY lab

Delivering Yesterday and Preparing for Tomorrow

